

Pick & Carry Cranes

A New Generation Of Pick

GF42 Pick & Carry Crane

[4.2t x 0.7m]

The GF42 is the big brother of the popular GF30 Pick & Carry Crane, offering up to 4.2t capacity up to a height of 0.7m in a compact machine, this crane is ideal for manoeuvring heavy loads in restricted access areas.

This compact radio controlled Pick & Carry Crane has a maximum working height of 7.6m, that extends to 8.4m with the optional searcher hook.

With 180° rear wheel steering, the GF42 gives operators total control in tight spaces such as those found in warehouses, factories, workshops, power plants, refineries and production lines.

100% battery powered means operators have zero emissions to deal with so no hazardous fumes and also helps companies meet government set emission goals.

The GF42 Pick & Carry crane is ideal for also working with our wide range of glass, stone or cladding vacuum lifters to help install glazing, facades, GRC panels and more.

Optional extras include a searcher hook, full winch system, auto levelling forks and low marking tyres.

Reference Code

MCGF42



Technical Specification

Capacity	4.2t x 0.7m
Maximum working radius	5.2m (6m with searcher hook)
Maximum lifting height	7.6m (8.4m with searcher hook)
Dimensions	2680mm (l) x 930mm (w) x 1500mm (h)
Weight	4500kg (w/ counterweights), 3000kg (without)
Boom length	2.68 - 7.18m (7.98m with searcher hook)
Boom type	3 section box boom (1+2 hydraulic, 3 manual)
Derricking angle	-10° to 65°
Steering	rear 180°
Tyres	2 solid rear, 2 solid front
Power source	24v rechargeable battery
Battery charger	110v
Travel speed	3km/h
Gradability	±20° (without load)
Standard equipment	Radio remote control, digital safe load indicator with display, radio-controlled proportional distributor, reversing alarm, emergency stop button, work light
Optional equipment	Searcher hook, jib, buckets, full-winch system, low marking tyres, auto-levelling hydraulic system with front tool holder plate, forks, fork shifters

Technical Data (approx. mm)

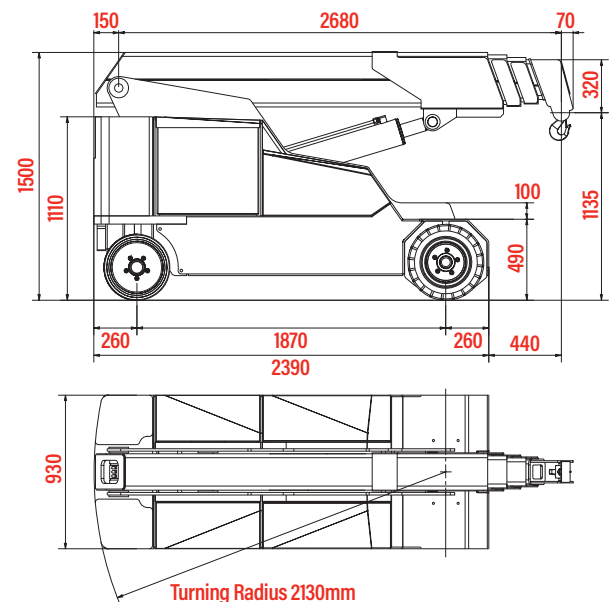

Standard radio remote



Optional searcher hook

Optional forks (1500kg Capacity)

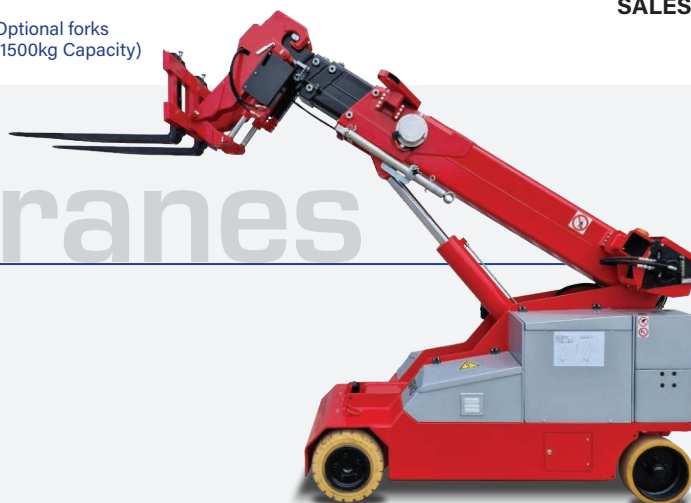

Optional winch



Maximum Working Height: 7.6m



Turning Radius: 2.13m

Main Hook & Searcher Hook Rated Loads

