

# Glass Vacuum Lifters

# Bestseller Built For Safe

## P11104 Intelli-Grip Dual Circuit [320kg]

This bestselling glass vacuum lifter is a convenient tool for lifting glass, metal, ceramics and other non-porous materials. The P11104 enables users to quickly manoeuvre loads into position with its 90° manual left & right rotation and 90° manual tilt.

The P11104 vacuum lifter now includes innovative Intelli-Grip technology as standard. This pioneering safety feature monitors vacuum lifter performance, carrying out multiple diagnostics and communicating them live on a colour LCD screen. This allows the operator to determine issues such as leak rate, battery life and current lifter mode in use, but also serves as a diagnostic system for the use of the equipment.

Engineered and tested for its reliability, safety and durability, the P11104 lifter comes with a 320kg lifting capacity and on-board power with a rechargeable battery, so there are no tricky cords to deal with during operation.

An optional short hook (hire only) is also available when fitting glass under soffits or overhangs.

### Key Features

- Capacity: 320kg
- Dual circuit vacuum system with reserve tank, non-return valve and vacuum gauge for each circuit
- 90° manual tilting from vertical to horizontal
- 90° manual left and right lockable rotation
- Integral maintenance-free vacuum pump
- 12v rechargeable battery with integral 110v or 240v charger and battery energy gauge
- On-board Intelli-Grip control panel



### Technical Specifications

<b>Safe working load</b> (smooth, clean surface at 60% vacuum)	capacity:	320kg
<b>Number of suction cups</b>	cups:	4
<b>Suction cup</b>	description:	black rubber, not abrasion resistant, heat resistant up to 100°F
<b>Suction cup diameter</b>	diameter:	305mm
<b>Suitable for lifting</b>	material properties:	gastight / non-porous
	surface:	smooth
	example:	glass, plastic boards, ceramic plates, sheet metals, coated boards
<b>Weight of lifter</b>	approx:	44kg
<b>Depth of lifter</b>	depth:	230mm
<b>Rotation</b>	rotation:	90° manual left & right lockable
<b>Tilt</b>	tilt:	90° manual
<b>Vacuum system</b>	dual circuit:	1 pump, 2 vacuum reserve tanks
<b>Voltage</b>	pump:	12v DC from rechargeable battery
	battery charger:	110v/240v 50/60Hz single phase factory selectable
<b>Optional accessories</b>	optional:	short hook (eye bolt - hire only), radio remote control, curved pads (270kg capacity), stone pads (270kg capacity), low marking pads, heat resistant pads

ety



Radio remote control as standard

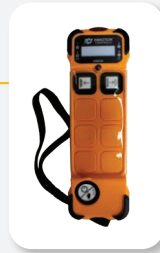

Reference Code  
**VGL11 IG**



The Intelli-Grip technology monitors vacuum lifters in real-time.

P11104 "Four-In-Line" Dual Circuit

**Technical Data (mm)**

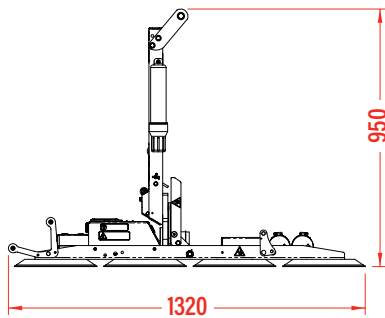
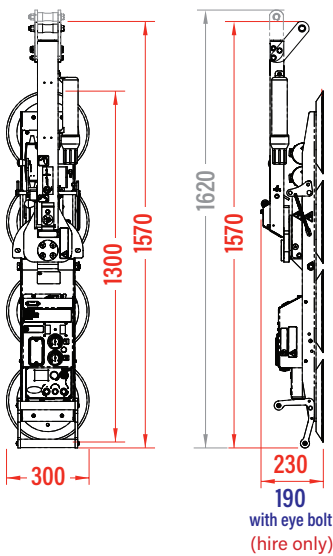

Optional short hook (eye bolt) upgrade (hire only)

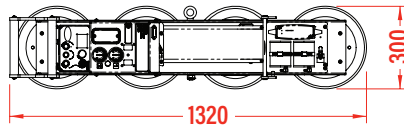

N.B. No rotate or tilt with short hook (eye bolt)

**Lift Bar Option - 635kg**

