

# Pick & Carry Crane

## MC32S Pick & Carry Crane [3.2t x 0.3m]

The MC32S is a radio remote controlled floor crane designed to lift and shift up to 3200kg loads in narrow spaces, with the operator in full control of all movements via the supplied radio remote, able to lift to a maximum height of 6.5m in total safety.

100% electric and offering up to 8 hours of battery life before needing charging this versatile floor crane is perfect for use in sensitive environments such as shopping centres, museums, aerospace, chemical and petrochemical, glass making, military or the food industry.

At just 980mm wide and 2785mm long the MC32S is ideal for confined lifting, and with the optional winch, fly jib, and low-marking tyres means this mini yet mighty machine can be even more versatile.

Weighing 3400kg with counterweights and with a steering radius of 2190mm, this nimble zero emissions floor crane is perfect for companies wanting to meet the net zero emissions goals of governments now and into the future.

### Key Features

- 3200kg capacity
- Maximum lifting height: 6m
- Maximum working radius: 4m
- Steering radius: 2.19m
- Weight: 3400kg (with 700kg removable counterweights)
- Optional hydraulic winch
- Optional fly jib
- Optional non-marking tyres

### Reference Code

MC32S



### Technical Specification

<b>Capacity</b>	3.2t x 0.3m
<b>Max working radius</b>	4m (5m with jib)
<b>Max lifting height</b>	6m (7.6m with jib)
<b>Dimensions</b>	2785mm (l) x 980mm (w) x 1695mm (h)
<b>Weight</b>	3,400kg (with removable 700kg counterweights)
<b>Boom type</b>	4 section box boom
<b>Derricking angle</b>	-15° to 60°
<b>Steering</b>	Rear hydraulic 180°
<b>Tyres</b>	2 solid rear, 2 solid front
<b>Travel speed</b>	12km/h
<b>Power source</b>	48V (500Ah) rechargeable battery
<b>Gradeability</b>	±11.3° (without load)
<b>Standard equipment</b>	digital safe load indicator with display, emergency stop button, work lights, radio remote control
<b>Optional equipment</b>	hydraulic winch, fly jib, non-marking tyres

### Technical Data (approx. mm)

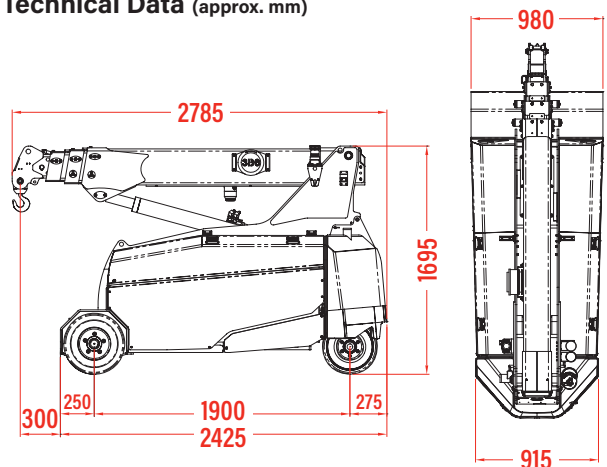



Optional non-marking tyres are available for the MC32S



The MC32S comes with a built-in SLI to aid operators on-site



The MC32S is fully controlled by radio remote with digital feedback display

Shown with optional hydraulic winch



Shown with optional fly jib

**Rated Loads**

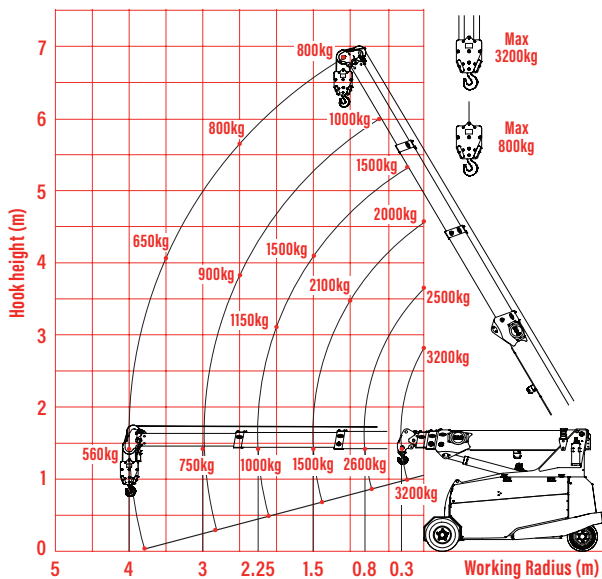

**Jib Rated Loads Chart**

