

Slewboy 500 Battery [500kg]

The Slewboy 500 Battery is a welcome upgrade to the industry favourite Slewboy 500, by making the machine fully battery powered, operators can move and install materials on-site both quicker and easier.

At just 990mm wide, this innovative crane benefits from a slewing arm enabling it to operate at 105° left and right of centre. With a maximum hook height of 3950mm the Slewboy 500 Battery is ideal for installing internal and external glazing, facades, balustrades and moving larger items around warehouses and construction sites.

This 500kg capacity counterbalance crane benefits from a maximum outreach of 1963mm (reducing capacity to 200kg) and can be transported by forklift to load onto vehicles or around site. The Slewboy 500 Battery is perfect for use with GGR's below-the-hook vacuum lifters for precision installation in a small package.

Reference Code

MCO32

Technical Specifications

Position 1	500kg	487mm
Position 2	300kg	1235mm
Position 3	200kg	1963mm
Weight	1100kg	
Max Hook Height	3950mm	
Max Outreach (hook to chassis)	1963mm	
Power Source	2 x 12v AGM with 110v battery charger	



The Slewboy 500 Battery with its clean layout of controls gives operators an easy to use way to complete lifts safely and quickly.



The tiller of the Slewboy 500 Battery is used to manoeuvre the machine around site and includes a body-bump safety button.

Technical Data (mm)

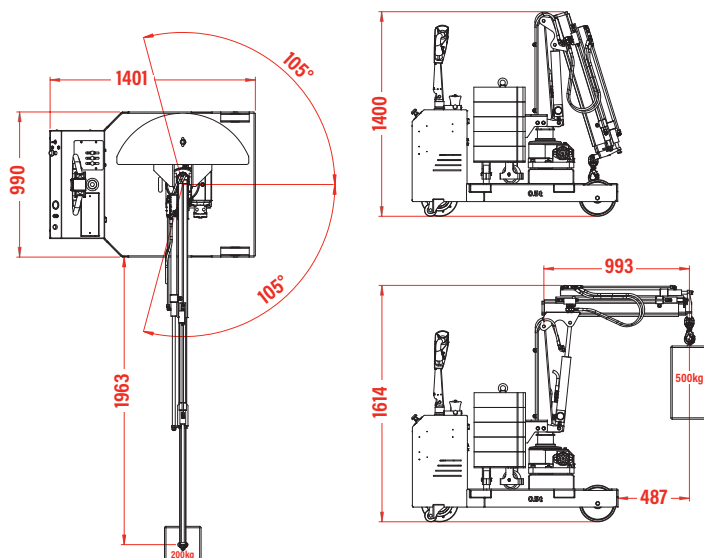

Rated Loads

